

HIGH CAPACITY HORIZONTAL FAN BOOSTER UNITS • ECM MOTOR MODEL: 35F • UNIT SIZES 3 AND 5

STANDARD FEATURES:

- 16 ga. (1.6) Galvanized steel channel frame with 20 ga. (1.0) casing components.
- 3/4" (19) dual density insulation, exposed edges coated to prevent air erosion. Meets the requirements of NFPA 90A and UL 181.
- Top and bottom full size access panels for ease of maintainance and service.
- Ultra-energy efficient ECM fan motor with overload protection. Solid state EPIC fan volume controller.
- Motor blower assembly mounted on special 16 ga. (1.6) angles and isolated from casing with rubber isolators.
- Single point electrical connection.
- Discharge opening designed for flanged duct connection.
- Extended insulated plenum reduces radiated sound levels.
- Controls mounted as standard on RH side as shown. Terminals ordered with left hand controls (optional) are inverted and discharge duct hanging location will therefore change.

OPTIONS:

- Nailor Direct Digital Controller (BACnet compliant).
- Nailor Analog Electronic Controls.
- 1" (25) throwaway fiberglass media filter.
- 1" (25) MERV 7 pleated disposable filter.
- Toggle disconnect switch.
- Fiber-free liner.
- Perforated metal liner.
- Steri-liner.
- Solid metal liner.
- Hanger brackets.
- Left-hand controls location / configuration.

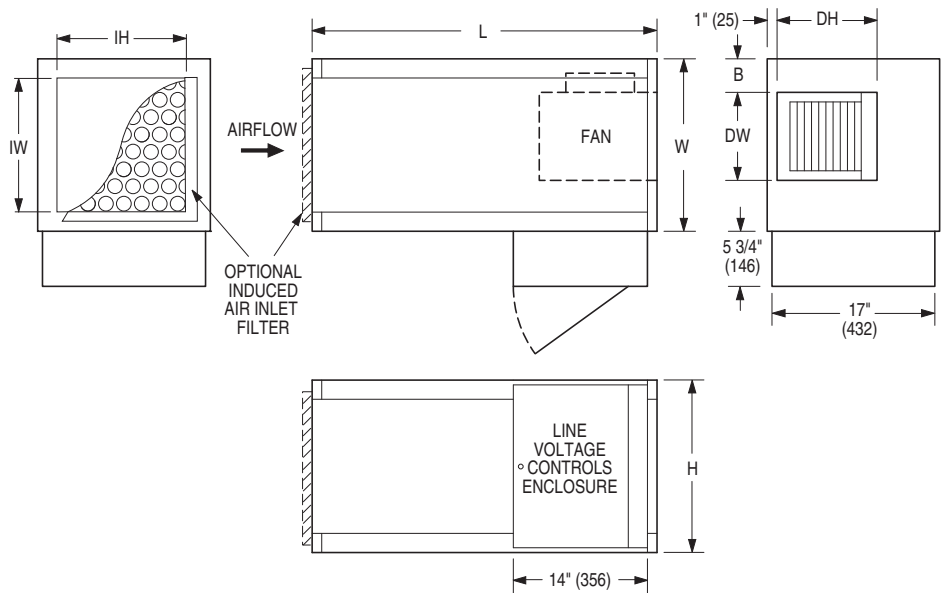

Dimensional Data. Imperial Units (inches)

Unit Size	W	H	L	B	Inlet IW x IH	Outlet Discharge DW x DH	Filter Size
3	18	18	36	3 1/2	14 x 14	9 1/4 x 10 1/2	16 x 16
5	26	18	41	5	22 x 14	13 1/4 x 11 1/2	24 x 15 1/2

Dimensional Data. Metric Units (mm)

Unit Size	W	H	L	B	Inlet IW x IH	Outlet Discharge DW x DH	Filter Size
3	457	457	914	89	356 x 356	235 x 267	406 x 406
5	660	457	1041	127	559 x 356	337 x 292	610 x 394

Electrical Data

Unit Size	Motor H.P.	ECM Motor			
		Voltage	120/1/60	208/240/1/60	277/1/60
3	1/2	Watts	532	500	433
		FLA	7	3.6	3.1
5	3/4	Watts	820	796	690
		FLA	10	5.9	5.1

All ECM motors are single phase, 50/60 Hz.
FLA = Full load amperage

SCHEDULE TYPE:

PROJECT:

ENGINEER:

CONTRACTOR:

Dimensions are in inches (mm).

DATE

B SERIES

SUPERSEDES

DRAWING NO.

6 - 16 - 08

35F

8 - 16 - 06

35FB-1