

Receiving Inspection

After unpacking the fan coil unit, check it for shipping damage. If any shipping damage is found, report it immediately to the delivering carrier. Store units in a clean, dry location.

Caution: The unit should only be lifted by its case. Never use the pipe connections as handles.

Supporting the Assembly

For model series 35F or 37F. Suspend the unit from the building structure in a horizontal plane. Be careful not to obstruct the access panels with support channels or straps. When requested, unit is supplied with field mounted hanger brackets for use with hanger rod up to 3/8" (9.5) dia. Hanger brackets or straps should be screwed to the top corner posts, unit casing sides, or alternatively onto the inlet and outlet ends of the unit if the top corner posts are not accessible. Fan coil units are too heavy to suspend with the ductwork they must be independently supported.

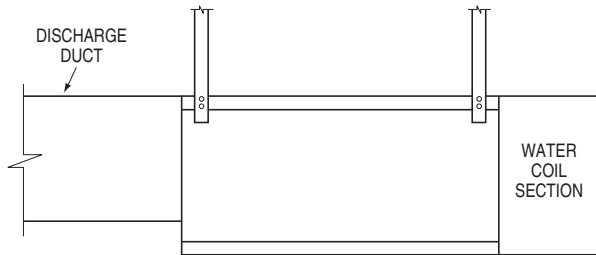

Figure 1: Fan Coil Unit Support Using Hanger Straps (For model series 35F and 37F).

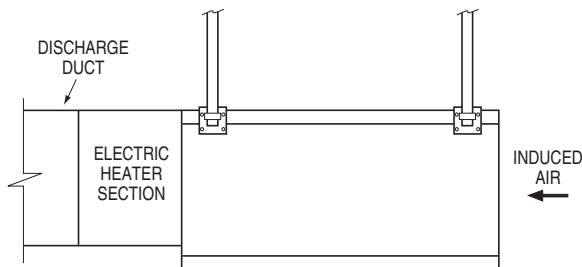

Figure 2: Fan Coil Unit Support Using Hanger Baskets and Rods (For model series 35F and 37F).

Nailor recommends attaching straps or screws into the 18-gauge frame of the 35F Series units for mounting, when possible, as shown in the figures below.

Minimum Access

Make appropriate accommodations for access panel removal. Nailor 35F units have access panels on the top, bottom and sides. Model 37F units have top and bottom panels. Model 38F units have only top panels. For low voltage control enclosure access, a minimum of 18" (457) is recommended for Model series 35F and 37F. Specific control enclosure location is indicated on product submittals. Low voltage control enclosures have removable covers that are attached with sheet metal screws. High voltage controls enclosures have access panels that are equipped with hinges. For clearances for full opening of hinged access doors, refer to project specifications, submittal sheets and NEC.

Important: These recommendations do not preclude NEC or local codes that may be in effect, which are the responsibility of the installing contractor.

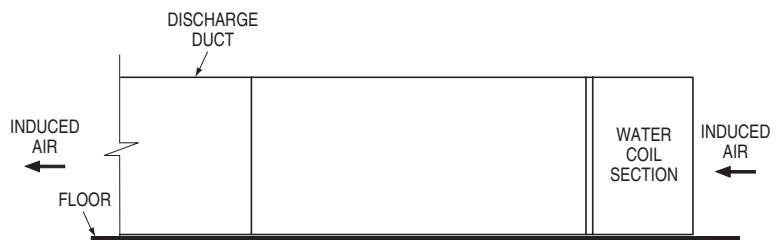

Figure 3: Fan Coil Unit Support Sitting On The Floor (For model series 38F).

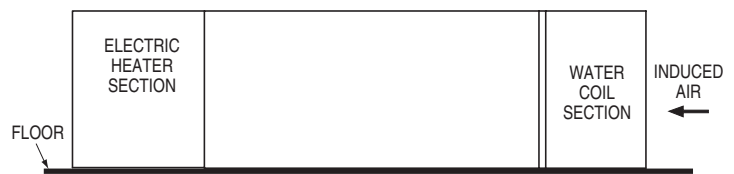

Figure 4: Fan Coil Unit Support Sitting On The Floor (For model series 38F).

Warning:

On model series 35F, when the control box is mounted left handed the distance from the top of the unit to the top of the blower opening is 1 inch. When the control box is mounted right handed the distance from the top of the unit to the top of the blower opening is 5 inches. This should be taken into consideration when the duct work is designed.

Field Wiring

All field wiring must comply with NEC and local codes. Disconnect switches are optional. Also, electrical, control, and piping diagrams

can be found on labels affixed to the exterior/interior of the control enclosure box. Unless specifically requested by customer, all units are wired for a single point connection to the fan and electric heater (if present). All electric heaters will be staged per specification. Motors rated for 277 or 120VAC on units with 480 or 208VAC ratings respectively are always connected between the neutral and L1 terminals. The installing electrician should rotate the incoming electric service by phase to help balance the building electric load. Fuse size designates the size of the internal fuse if it is supplied. Maximum Overcurrent Protection (MOP) designates the largest breaker or fuse in the electrical service panel that can be used to protect the unit.

Dimensions are in inches (mm).

ELECTRICAL SUGGESTIONS AND REQUIREMENTS:

1. Provide a safety disconnect per NEC 424-19, 20, 21
2. Disconnect the power supply before wiring or servicing unit. If a disconnect switch is present, it should be in the OFF position while making power connections or repairs.
3. All units with electric heat should have copper wires sized for 125% of Nameplate Amperage.
4. Follow wiring diagrams and instructions mounted on the unit. 480V/3 phase heaters, for example, require a neutral wire in addition to the full sized ground wire. NEC 424-15 and 250 also require that all units be grounded.

Cooling / Heating Connections

Caution: Toxic residues and loose particles resulting from manufacturing and field piping techniques may be present in the unit and piping system. Special consideration must be given to system cleanliness if unit is to be connected to solar, domestic, or potable water systems.

Submittals and Product Catalogs detailing unit operation, controls and connections should be thoroughly reviewed **BEFORE** beginning the connection of the various cooling and/or heating mediums to the unit.

All accessory valve packages should be installed as required, and all service valves should be checked for proper operation.

In cases where control valves are field installed, care should be taken to insure the valve body is not overheated when braze connections are made.

All pipe screw connections must be made using a "backup wrench" to insure the copper tube is not twisted during the tightening sequence. If unions are used, over tightening should be avoided to prevent distortion to the union seal surfaces and destroying the union.

Factory installed screw connections have been tightened and tested at the factory before shipping. These connections must be checked for tightness in the field before unit is put into service to ensure fittings did not loosen due to shipping vibration.

Control Start-up and Operation

Your local Nailor Representative can provide detailed information about start-up and operating procedures for Nailor's digital, analog, and pneumatic controls. For specific information on controls provided by other manufacturers contact the control manufacturer's local or national office. This applies whether the controls were factory or field installed.

Note: Digital controllers may use specific communication addresses based on Building Management Systems, Architecture and original engineering drawings. Installing the fan coils in a location other than that noted on the label may result in excessive start-up labor.

Fan Adjustment

Before starting the fan motor, make sure duct system is free of foreign objects, and filters are installed where required.

- (1) Start motor and let it run-in at least 15 minutes. During run-in, check ductwork connections for leaks and repair if necessary.
- (2) These units are equipped with ECM motors. Set the fan as described on the ECM MOTORS IOM, page 1.

Maintenance Procedures

Fan and Motor

Nailor fan coil units are equipped with permanently lubricated motors. Inspect fan and motor assembly for dust and dirt as often as dictated by operating environment clean assembly if necessary.

If fan motor does not run, do the following:

- a. Check for free rotation of blower wheel. Make sure no foreign objects are in fan. Look for signs of freight or job site damage.
- b. Check power supply. Disconnects should be in the "ON" position. Optional fusing should also be inspected. Check transformer for proper output.
- c. Check for proper control signals and PE switch setting (if provided) and relay function.

Fan motor runs but emits excessive noise:

- a. Maximum airflow may be too high, or discharge static pressure may be incorrect.
- b. Blower may have clearance problems. Make sure all components are securely attached.
- c. Verify integrity of ductwork. Leaks or loose connections could cause noise. Check for rattling diffusers or rattling or incorrectly adjusted balancing dampers.

Fan motor runs, but airflow too low:

- a. May be due to ductwork restrictions, dirty air filters, or clogged water coils.
- b. Readjust fan speed control.
- c. Discharge static pressure may be incorrect.

If repair or replacement is required:

Disconnect all power before servicing. Motor and fan should be removed as an assembly. Remove the four hex nuts from the mounting lugs holding the fan assembly to the discharge panel, and remove the assembly through any convenient access panel. Do not allow assembly to hang from wiring. If removing motor from blower, first loosen the setscrew holding the blower wheel to the motor shaft. Remove the three screws holding the motor to the fan housing, and slide motor and fan housing apart.

To put the assembly back together, reverse the procedure. Be sure to align the blower set screw with the flat section of motor shaft.

Note: Over-tightening motor mounting screws may crush isolation bushing, causing excessive fan noise.

Dimensions are in inches (mm).

Labels

Each fan coil unit is shipped with a nameplate label affixed to the control casing. Principle nameplate data on the label typically include Order-Serial number, Model number, Unit size, Motor horsepower, Amperage, MOP, Heater (if present) data, Supply Voltage, and Airflow. Also provided are calibration, airflow, as well as other labels as necessary. We suggest that you read all labels before beginning installation. If you have any questions, please contact your local Nailor Representative. Their phone numbers can be found on our website at www.nailor.com.

airflow, as well as other labels as necessary. We suggest that you read all labels before beginning installation. If you have any questions, please contact your local Nailor Representative. Their phone numbers can be found on our website at www.nailor.com.

Nameplate Label



FAN COIL UNIT

DATE (DATE)	: 15-Sept-3000	SERIAL NO. (NO. DE SÉRIE)	: 155258-10
MODEL (MODÈLE)	: 35FE	TAG NO. (NO. DÉTIQUETTE)	: 42
UNIT SIZE-INLET SIZE (DIAMÈTRE D'ENTRÉE)	: 3	VOLTAGE (VOLTAGE)	: 480
CONTROL VOLTAGE (VOLTAGE DE CONTRÔLE)	: 24	PHASE (PHASE)	: 3
CONTROL SEQUENCE (SEQUENCE DE CONTRÔLE)	: DF	STAGES (ÉTAPES)	: 2
VOLT AMP (VOLT-AMPÈRE)	: 50	HZ. (HZ)	: 50/60
HOT WATER COIL ROWS (NOMBRE DE RANGÉES SERPENTIN EAUCAUDE)	: N/A	MOTOR HP (MOTEUR HP)	: 1/2
		MOTOR VOLTAGE (VOLTAGE DU MOTEUR)	: 227
		MOTOR AMP (AMPERAGE DU MOTEUR)	: 3.5

	KW/HP			AMPS (AMPÈRES)			AMPACITY (AMPACITÉE)			MAX. OVERCURRENT PROTECTION (RESISTANCE DES FUSIBLE MAX.)		MOTOR FUSE SIZE (MOTEUR FUSIBLE)
	TOTAL (TOTALE)	EACH CIR. (CHAQUE CIRCUIT)	EACH STG. (CHAQUE ÉTAPE)	TOTAL (TOTALE)	EACH CIR. (CHAQUE CIRCUIT)	EACH STG. (CHAQUE ÉTAPE)	TOTAL (TOTALE)	EACH CIR. (CHAQUE CIRCUIT)	EACH STG. (CHAQUE ÉTAPE)	TOTAL (TOTALE)	EACH CIR. (CHAQUE CIRCUIT)	
HEATER (CHAUFFAGE)	6.0	6.0	3.0	7.2	7.2	3.6	9.0	9.0	4.5	15	15	10
MOTOR (MOTEUR)	1/4			3.5			4.4					3.0
TOTAL (TOTALE)				10.7			13.4					

EACH ELEMENT RATED @ 2.0 KW @ 277 VAC. AWG. MIN. WIRE SIZE (MIN DIAMÈTRE DE FIL) : 14

(CHAQUE ÉLÉMENT CLASSIFIER A) MIN. HEATING CFM (MIN. PCM) : 420

USE WIRE SUITABLE FOR AT LEAST 75 °C
L1 IS COLOR CODED BLACK, L2 IS BLUE, L3 IS RED
CONTROL WIRES CODED AS MARKED
USE COPPER CONDUCTORS ONLY.

UTILISER UN FIL MÉTALLIQUE QUI CONVIENT AU MOINS 75 °C
L1 EST COLORÉ NOIR, L2 EST BLEU, L3 EST ROUGE,
LES FILS DE CONTRÔLE SONT IDENTIFIÉS COMME MARQUÉS,
UTILISÉ DES CONDUCTEURS DE CUIVRE SEULEMENT.

USE CLASS K, RK1, A2D OR A6D FUSE OR HACR BREAKERS.
FAN CFM: 890

UTILISÉ DES FUSIBLES CLASS K, RK1, A2D, OU A6D OU HACR DISJONCTEURS.
FAN L/S: 420

Application charts for ECM motors

A. Sample VDC vs. CFM Chart

Nailor Industries Inc. ECM MOTOR FAN CALIBRATION TABLE											
CFM vs VDC (Imperial Units)											
MODEL SERIES: 35F UNIT SIZE 3 - 1/2 H.P. 277 VAC.											
FAN COIL UNIT											
CFM	PWM VDC INPUT	0-10	CFM	PWM VDC INPUT	0-10	CFM	PWM VDC INPUT	0-10	CFM	PWM VDC INPUT	0-10
0	0	0	480	3.50	2.45	816	7.00	4.90	1114	10.50	7.36
136	0.10	0.06	491	3.60	2.52	824	7.10	4.97	1123	10.60	7.43
144	0.20	0.13	501	3.70	2.59	833	7.20	5.04	1131	10.70	7.50
152	0.30	0.20	512	3.80	2.66	841	7.30	5.11	1140	10.80	7.57
161	0.40	0.27	522	3.90	2.73	850	7.40	5.18	1149	10.90	7.64
170	0.50	0.34	533	4.00	2.80	859	7.50	5.25	1158	11.00	7.71
179	0.60	0.41	543	4.10	2.87	867	7.60	5.32	1166	11.10	7.78
188	0.70	0.48	553	4.20	2.94	876	7.70	5.39	1175	11.20	7.85
197	0.80	0.55	563	4.30	3.01	884	7.80	5.46	1184	11.30	7.92
207	0.90	0.62	573	4.40	3.08	893	7.90	5.53	1193	11.40	7.99
216	1.00	0.69	584	4.50	3.15	901	8.00	5.60	1201	11.50	8.06
226	1.10	0.76	594	4.60	3.22	909	8.10	5.67	1210	11.60	8.13
236	1.20	0.83	603	4.70	3.29	918	8.20	5.74	1219	11.70	8.20
246	1.30	0.90	613	4.80	3.36	926	8.30	5.81	1228	11.80	8.27
256	1.40	0.97	623	4.90	3.43	935	8.40	5.89	1236	11.90	8.34
267	1.50	1.04	633	5.00	3.50	943	8.50	5.96	1245	12.00	8.41
277	1.60	1.11	643	5.10	3.57	952	8.60	6.03	1254	12.10	8.48
288	1.70	1.18	652	5.20	3.64	960	8.70	6.10	1262	12.20	8.55
298	1.80	1.25	662	5.30	3.71	968	8.80	6.17	1271	12.30	8.62
309	1.90	1.32	671	5.40	3.78	977	8.90	6.24	1279	12.40	8.69
319	2.00	1.39	681	5.50	3.85	985	9.00	6.31	1288	12.50	8.76
330	2.10	1.46	690	5.60	3.92	994	9.10	6.38	1296	12.60	8.83
341	2.20	1.53	699	5.70	3.99	1002	9.20	6.45	1305	12.70	8.90
352	2.30	1.60	709	5.80	4.06	1011	9.30	6.52	1313	12.80	8.97
362	2.40	1.67	718	5.90	4.13	1019	9.40	6.59	1321	12.90	9.04
373	2.50	1.75	727	6.00	4.20	1028	9.50	6.66	1329	13.00	9.11
384	2.60	1.82	736	6.10	4.27	1036	9.60	6.73	1337	13.10	9.18
395	2.70	1.89	745	6.20	4.34	1045	9.70	6.80	1345	13.20	9.25
406	2.80	1.96	754	6.30	4.41	1053	9.80	6.87	1353	13.30	9.32
416	2.90	2.03	763	6.40	4.48	1062	9.90	6.94	1361	13.40	9.39
427	3.00	2.10	772	6.50	4.55	1071	10.00	7.01	1368	13.50	9.46
438	3.10	2.17	781	6.60	4.62	1079	10.10	7.08	1376	13.60	9.53
448	3.20	2.24	789	6.70	4.69	1088	10.20	7.15			
459	3.30	2.31	798	6.80	4.76	1097	10.30	7.22			
470	3.40	2.38	807	6.90	4.83	1105	10.40	7.29			

THIS UNIT HAS BEEN FACTORY SET AT _____ CFM.

RE-CALIBRATION IS NOT REQUIRED UNLESS THE ZONE DESIGN AIRFLOW REQUIREMENT HAS CHANGED. FOR CALIBRATION INSTRUCTIONS, REFER TO BULLETIN WVECM. CAUTION IF CALIBRATING IN SHADED AREA. AT LOW VOLUMES, VARIATIONS IN FLOW FROM COOLING TO HEATING MAY BE GREATER THAN 5%. AT HIGH VOLUMES, NOISE MAY BE EXCESSIVE.

SUBJECT TO CHANGE WITHOUT NOTICE

B. Sample Application AMP/CFM Chart

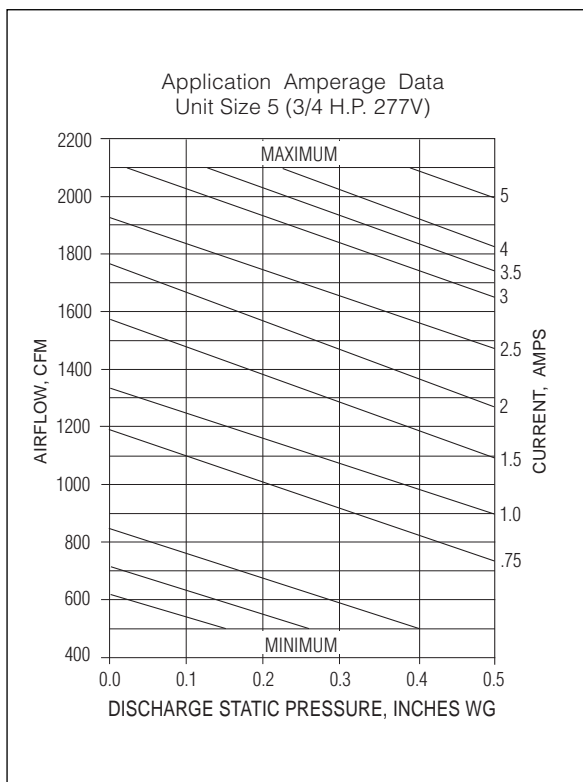

LCD Analog Thermostat

SPECIFICATIONS

Supply Voltage: 14 - 19 VDC
 Set Point Range: 60 - 85°F (15.6 - 29.4 °C)
 (Power On Default: 70°F / 21.1°C)

TEMPERATURE SENSOR TYPE:

Thermistor
 Accuracy: +/- .36°F (.2°C)
 Display Degrees F or C:
 Select Table (Factory Setting: Degrees F)
 Direct Acting Output: 0 - 10 VDC
 Min./ Max. Limits: Adjustable 0 - 100%
 (Factory Settings: Min. = 20, Max. = 100)
 Proportional Band: 2 - 6 F (1.1 - 3.3 C)
 (Factory Setting: 4°F)
 Integration Time: 15 - 60 Minutes (0 = OFF)
 (Factory Setting: 30)

UNOCCUPIED SETPOINT MODES:

Off or Deadband
 (Factory Setting: OFF)
 Off Mode: Output Voltage = 0.0 Volts
 (Safety Override: Output Cycles
 0.0 Volts To 2.0 Volts
 To Maintain 50°F To 55°F)

DEADBAND MODE:

Integral Action Disabled & Set Point
 Set To Default +/- 10°F Deadband.
 Deadband Output Midway Between Max
 & Min.

TEMPERATURE OFFSET:

Adjustable +/- 2°F (+/- 1.1°C)
 (Press MIN & INT Together)

OPERATING AMBIENT:

34 - 125°F (1.1 - 51.6°C)

SHIPPING AMBIENT:

-40 - 140°F (-40 - 60°C)

HUMIDITY:

0 - 95% Non Condensing

CASE MATERIAL:

LIGHT ALMOND ABS
 UL FLAME CLASS 94HB

RJ-12 FEMALE CONNECTOR:

PIN1 NC PIN2 COM PIN3 SUPPLY
 PIN4 OUT PIN5 COM PIN6 NC

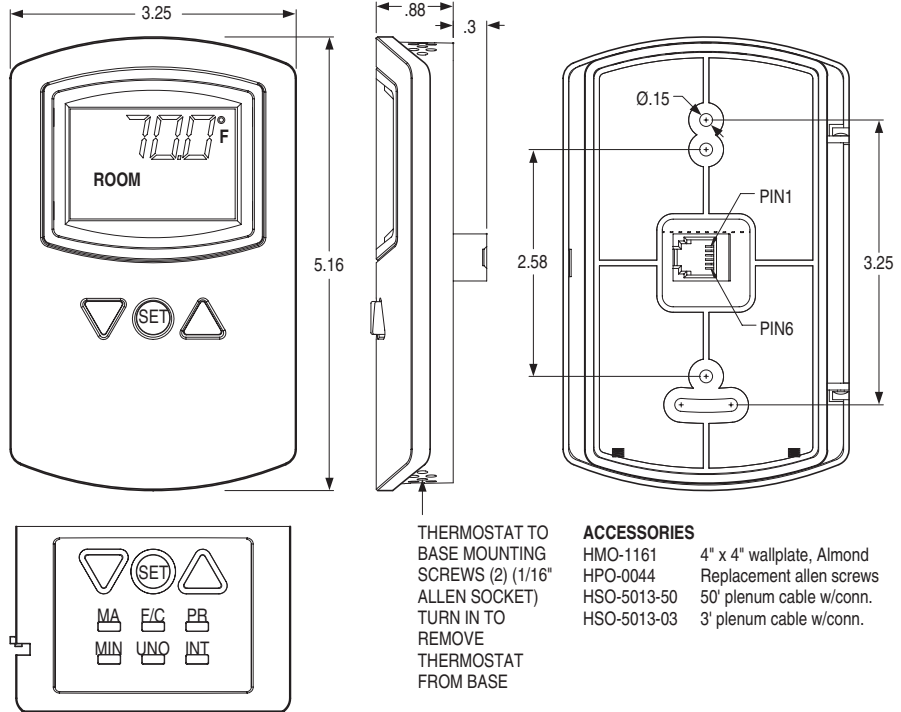

THERMOSTAT TO
 BASE MOUNTING
 SCREWS (2) (1/16"
 ALLEN SOCKET)
 TURN IN TO
 REMOVE
 THERMOSTAT
 FROM BASE

ACCESSORIES

HMO-1161	4" x 4" wallplate, Almond
HPO-0044	Replacement allen screws
HSO-5013-50	50' plenum cable w/conn.
HSO-5013-03	3' plenum cable w/conn.